

STR83145

LATCHED, UNIVERSAL INPUT-VOLTAGE SWITCHES

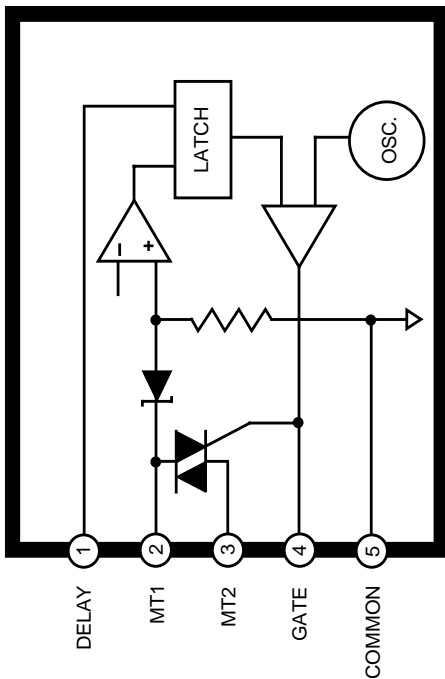

Dwg. PK-005

ABSOLUTE MAXIMUM RATINGS

Repetitive Peak OFF-State Voltage, V_{DRM}	500 V
Static ON-State Current, $I_{T(RMS)}$	10 A
Non-Repetitive Surge ON-State Current, I_{TSM}	100 A
Package Power Dissipation, P_D	See Graph
Triac Junction Temperature, T_J	+125°C
Frame Temperature, T_M	+100°C
Operating Temperature Range, T_A	-20°C to +125°C
Storage Temperature Range, T_{stg}	-40°C to +125°C

Intended for power supplies with universal inputs (85 V to 265 V rms), the STR83145 latch, universal input-voltage switch incorporates timing, control, and drive circuitry with a high-current triac (bidirectional triode thyristor) switch. The device senses the applied ac line potential and automatically switches the rectifier and associated capacitors between a voltage-doubler configuration (for line voltages to 141 V) and a full-bridge configuration (for line voltages greater than 149 V). This eliminates the possibility of user error with adjustable jumpers or switches. Also, the related switch-mode power stage need operate only over a reduced range of dc input voltages when compared with "wide input" power supplies using a bridge rectifier only. The reduction in dc input voltage range permits the use of lower-voltage capacitors and leads to a reduction in power stage stresses and power dissipation.

The internal sensitive-gate triac is switched by a temperature-compensated constant-current gate driver driven by a 15 kHz pulse train to reduce power dissipation. The switch-over voltage is accurately set during manufacture for consistent operation. A user-adjustable delay is provided to ensure start-up in the full-bridge mode. Once established (by an input voltage greater than 149 V rms), an integral latch holds the full-bridge mode to preclude false application of the doubler mode during brownouts, voltage droops, or missing cycles.

The requirements of low transient thermal impedance and steady-state thermal resistance are satisfied in a molded, 5-lead single in-line power package. Similar input-voltage switches, with a switch point of 159 V rms, are also available.

FEATURES

- Low Duty Cycle Triac Drive for Minimum Dissipation
- For Universal Input Operation Between 85 V rms and 265 V rms to 10 A
- Internal Latch Prevents False Mode Switching
- Internal Sensitive-Gate Power Triac
- Adjustable Start-Up Delay
- Accurate 145 V rms Switch-Point Voltage
- Low External Parts Count
- Low Power Dissipation
- Low-Power External Parts

Always order by complete part number, e.g., **STR83145** .

STR83145 LATCHED, UNIVERSAL INPUT-VOLTAGE SWITCH

FUNCTIONAL BLOCK DIAGRAM

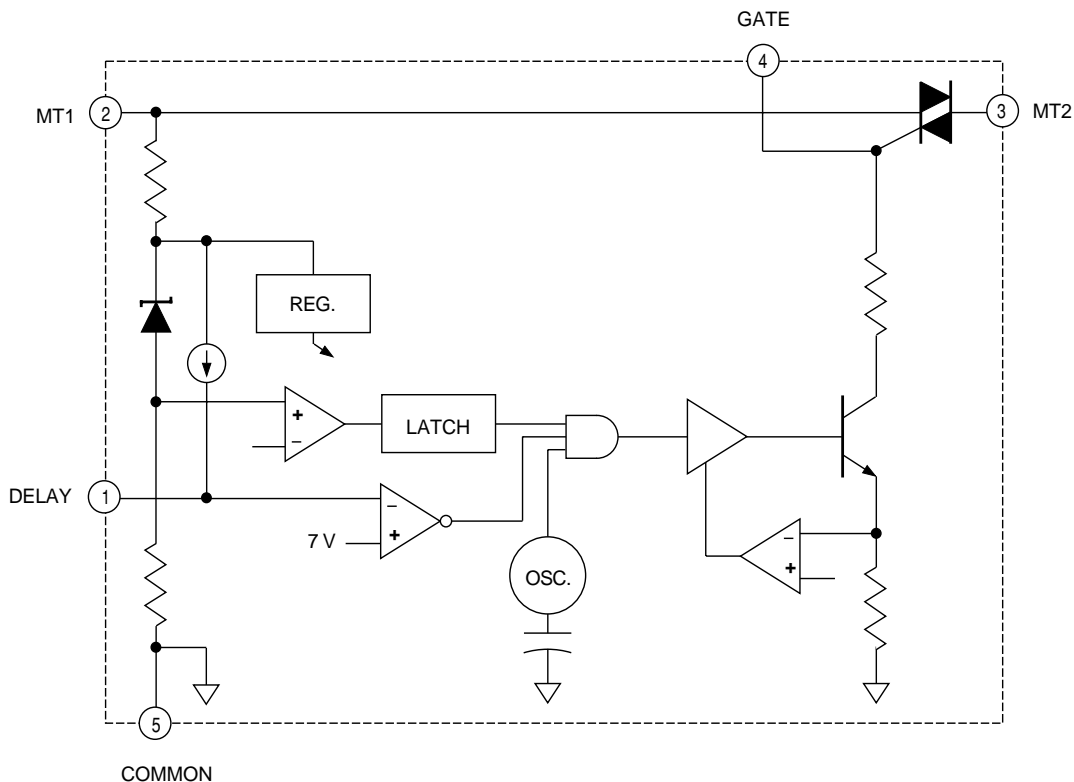

Dwg. FK-004

ALLOWABLE PACKAGE POWER DISSIPATION

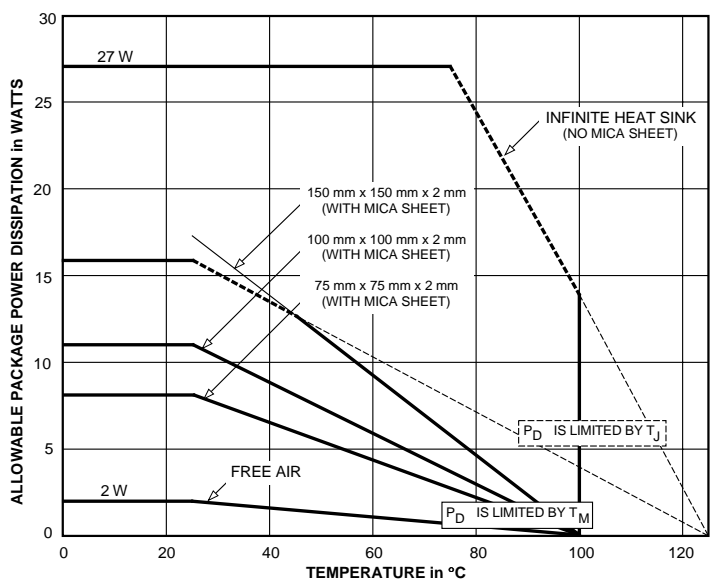

Dwg. GK-010

STR83145

LATCHED, UNIVERSAL INPUT-VOLTAGE SWITCH

SIMPLIFIED OPERATION

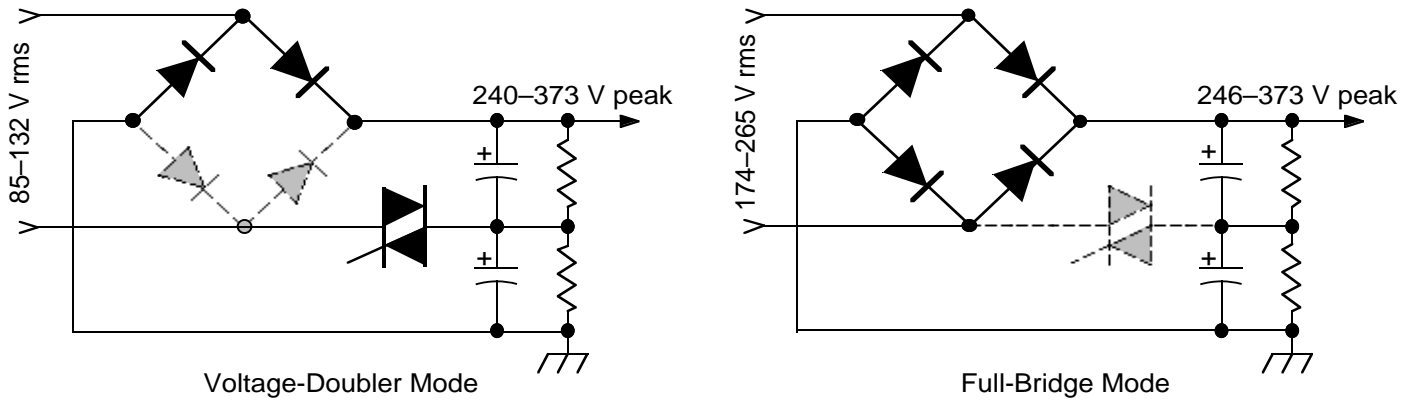

Dwg. EK-006

ELECTRICAL CHARACTERISTICS at $T_A = +25^\circ\text{C}$, voltage measurements are referenced to Common (pin 3) (unless otherwise noted).

Characteristic	Symbol	Test Conditions	Limits			Units
			Min.	Typ.	Max.	
On-State Voltage	V_{TM}	$I_T = 10\text{ A}^*$	-	-	1.8	V
Off-State Current	I_{DRM}	$V_D = 500\text{ V}$	-	-	100	μA
Starting Voltage	V_S	$V_T = 2\text{ V}$	-	-	100	V
Startup Time Delay	t_D	$C_2 = 1\ \mu\text{F}$, $V_{MT1} \geq 100\text{ V dc}$	40	-	100	ms
DC Switch-Over Voltage	V_C	$V_{DELAY} \leq 1\text{ V}$	200	205	210	V
Temperature Coefficient of Switch-Over Voltage	α_{VC}	$-20^\circ\text{C} \leq T_M \leq +100^\circ\text{C}$	-	± 45	-	mV/ $^\circ\text{C}$
Input Current	I_{MT1}	Voltage-doubler mode, $V_{MT1} = 195\text{ V}$	-	-	10	mA
		Full-bridge mode, $V_{MT1} = 400\text{ V}$	-	-	6.5	mA
Delay Terminal Voltage	V_{DELAY}		-	-	7.0	V
Triac Gate-Drive Osc. Freq.	f_o	V_{gate} ref. MT1, $V_{MT1} = 100\text{ V}$	-	15	-	kHz
Latch Reset Voltage	V_R	$V_{GATE} = 400\text{ mV}$	2.0	-	15	V
Thermal Resistance	$R_{\theta JM}$	FET channel to mounting surface	-	-	1.8	$^\circ\text{C/W}$

NOTES: Negative current is defined as coming out of (sourcing) the specified device terminal.

Typical Data is for design information only.

*In practical use, I_T is recommended derated to 70%.

STR83145

LATCHED, UNIVERSAL INPUT-VOLTAGE SWITCH

TYPICAL CHARACTERISTICS

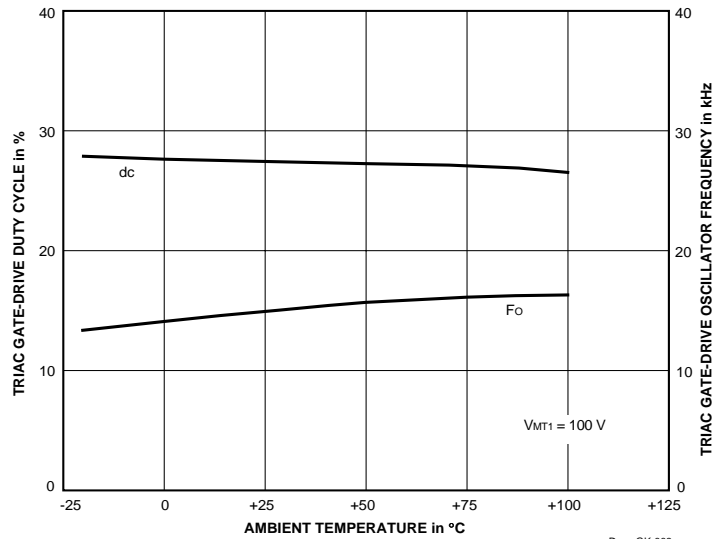
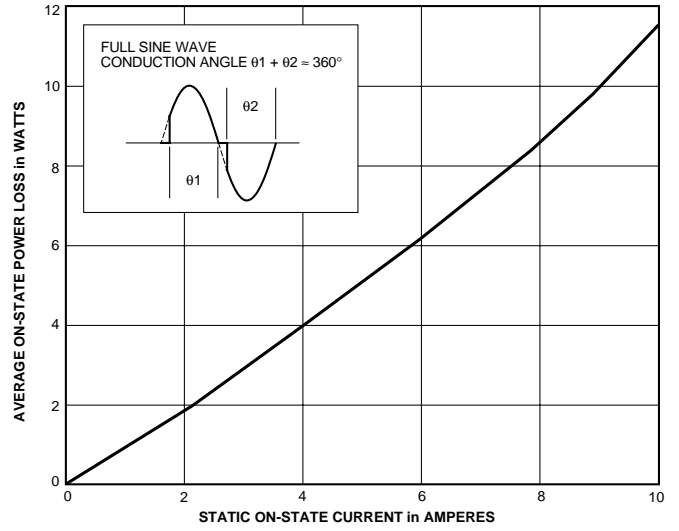
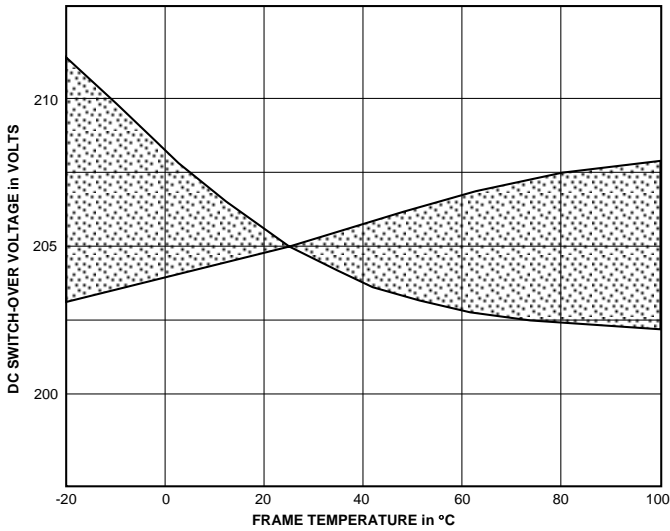

APPLICATIONS INFORMATION

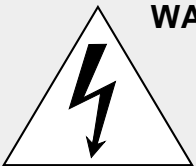

WARNING — These devices are designed to be operated at lethal voltages and energy levels. Circuit designs that embody these components must conform with applicable safety requirements. Precautions must be taken to prevent accidental contact with power-line potentials. Do not connect grounded test equipment.

The use of an isolation transformer is recommended during circuit development and breadboarding.

STR83145 LATCHED, UNIVERSAL INPUT-VOLTAGE SWITCH

TYPICAL APPLICATION

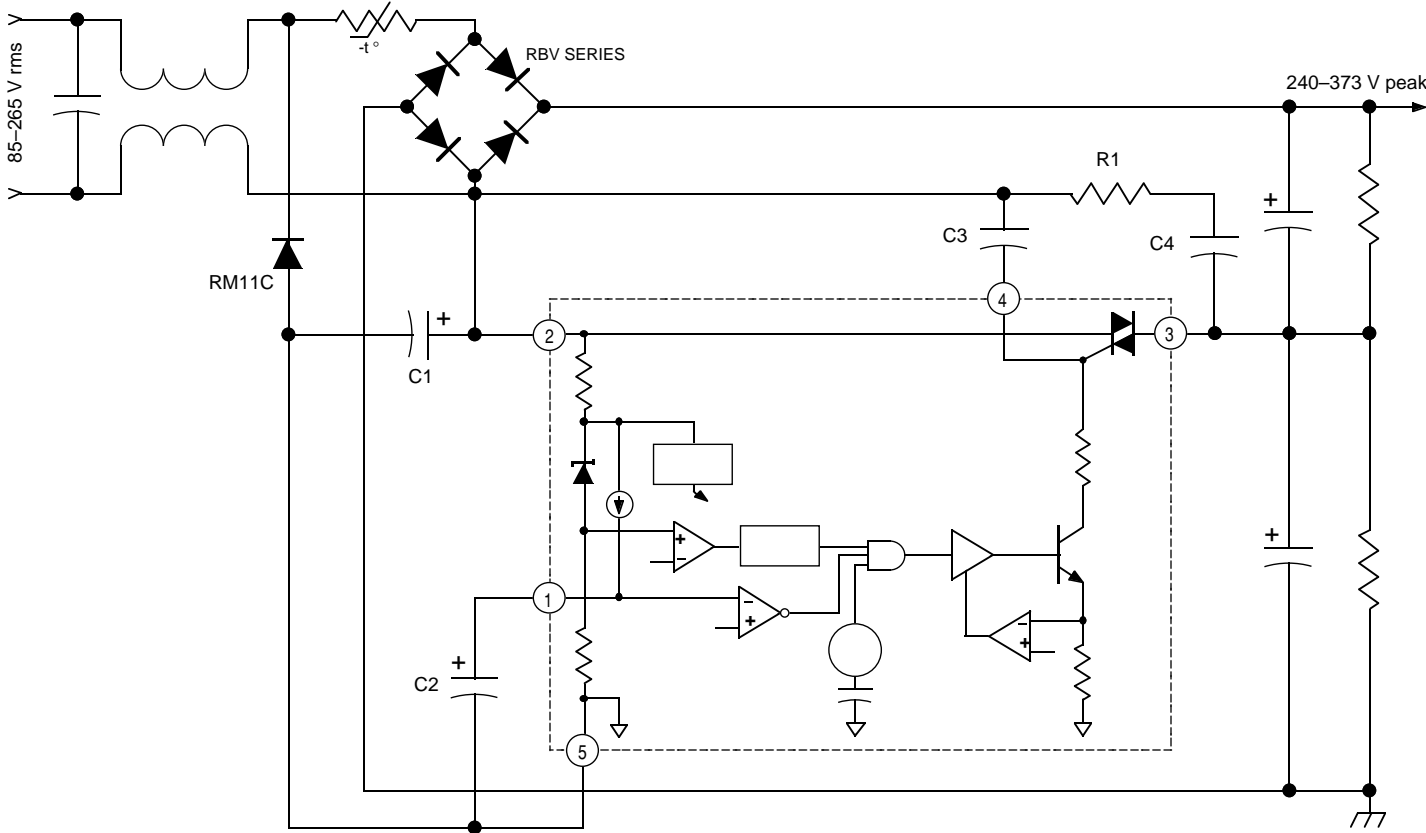

Dwg. EK-007

External component values have been selected for optimum device performance and reliability. Except for C_2 , component values other than the following may result in false operation of these devices.

- $C_1 = 4.7 \mu\text{F}, 400 \text{ V}$
- $C_2 = 1 \mu\text{F}, 50 \text{ V}$
- $C_3 = 0.047 \mu\text{F}, 50 \text{ V}$
- $C_4 = 0.047 \mu\text{F}, 250 \text{ V}$
- $R_1 = 4.7 \Omega$

Turn-ON delay (forced full-bridge mode) may be adjusted for desired system performance:

$$t_D \approx 68 \times C_2$$

where t_D is the delay time in ms
 C_2 is capacitance in μF

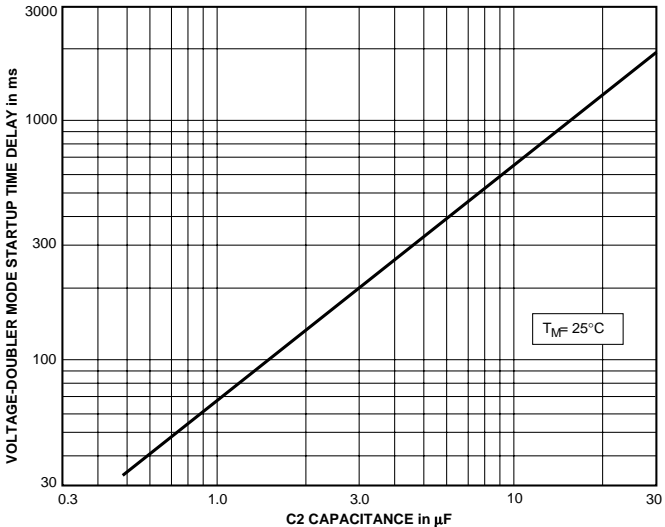

Dwg. GK-011

STR83145
LATCHED, UNIVERSAL
INPUT-VOLTAGE SWITCH

Dimensions in Inches
(for reference only)

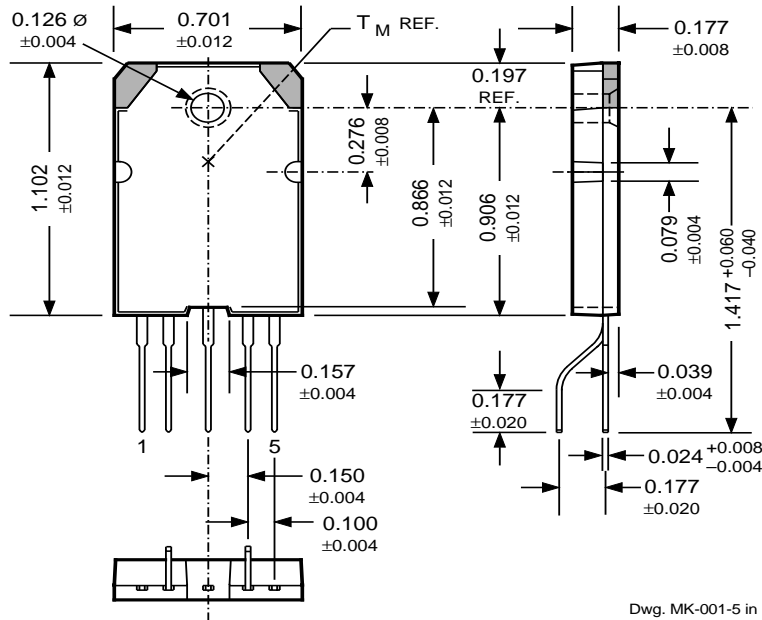

- NOTES:
1. Exact body and lead configuration at vendor's option within limits shown.
 2. Recommended mounting hardware torque: 4.34 – 5.79 lbf•ft.
 3. The hatched area is exposed heat spreader, electrically common to pin 3.
 4. Recommended 0.003" to 0.006" thick mica insulator with metal-oxide-filled, alkyl-degenerated oil base, silicone grease (Dow Corning 340, or equivalent); or Bergquist Sil-Pad®.

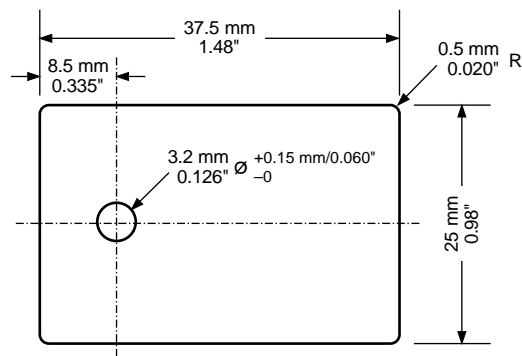

STR83145 LATCHED, UNIVERSAL INPUT-VOLTAGE SWITCH

Dimensions in Millimeters (controlling dimensions)

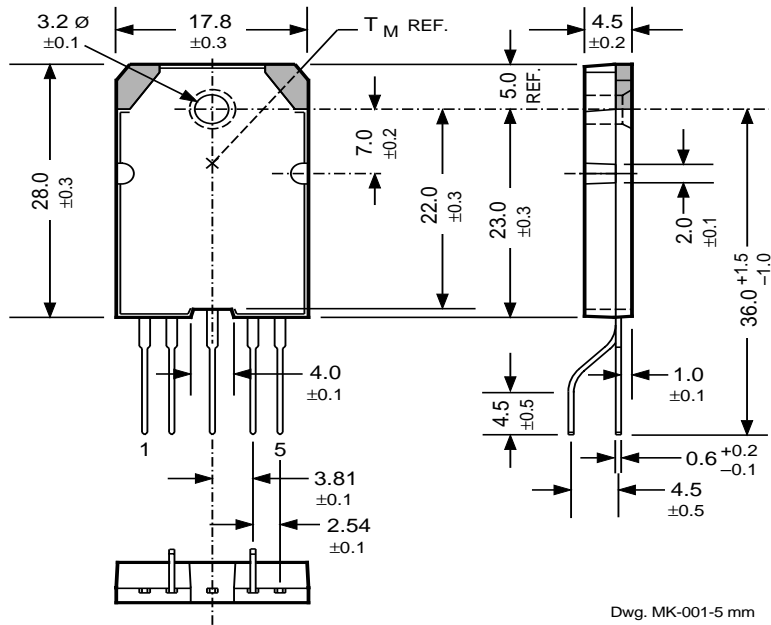

- NOTES:
1. Exact body and lead configuration at vendor's option within limits shown.
 2. Recommended mounting hardware torque: 6 – 8 kgf•cm (0.588 – 0.785 Nm).
 3. The hatched area is exposed heat spreader, electrically common to pin 3.
 4. Recommended 0.08 mm to 0.15 mm thick mica insulator with metal-oxide-filled, alkyl-degenerated oil base, silicone grease (Dow Corning 340, or equivalent); or Bergquist Sil-Pad®.

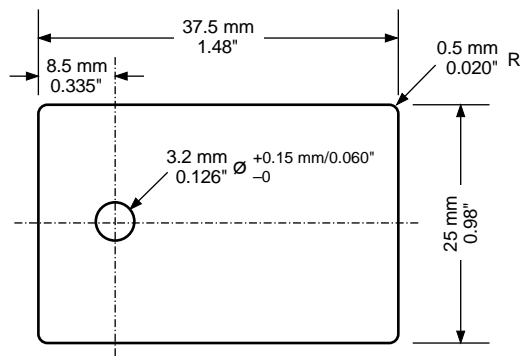

STR83145
LATCHED, UNIVERSAL
INPUT-VOLTAGE SWITCH

The products described here are manufactured in Japan by Sanken Electric Co., Ltd. for sale by Allegro MicroSystems, Inc.

Sanken Electric Co., Ltd. and Allegro MicroSystems, Inc. reserve the right to make, from time to time, such departures from the detail specifications as may be required to permit improvements in the design of their products.

The information included herein is believed to be accurate and reliable. However, Sanken Electric Co., Ltd. and Allegro MicroSystems, Inc. assume no responsibility for its use; nor for any infringements of patents or other rights of third parties which may result from its use.